

# STANDARD BIN UNLOAD

## HORIZONTAL BIN UNLOADING AUGER KITS

Unload your bins at the flip of a switch! This economical unit unloads from the center of the bin, reducing strain on the bin walls and allows you to sample from the center. It can be moved from bin to bin for added savings.

The horizontal unloading kit includes a section of flanged tubing (with flight and stubs) which bolts to the flange on the unloading tube. The motor is mounted on top of the tube. All mounts are designed to take the proper size motor. The head bearing is sealed and self-aligning. Drive parts include auger sheave and "B" belts for dependable service.

Grain discharges down from the bottom side. A utility auger or a portable auger can be combined with a horizontal bin unloader to load trucks.

Unit attaches to bin unloading tube. Unloading flight sold separately.

### 6" UNLOADING KIT (1500 BPH)

6"x16" long, 16ga. Galv. Tube w/ flange, stubs, motor mount, 11ga. Flight welded to 1.25" shafting, "B" belts and 12" auger sheave. Use 3.5" motor pulley for proper speed.

DESCRIPTION	WEIGHT	PRICE
6" HORIZONTAL BIN UNLOADER, 1-BELT	43 lbs.	★
6" HORIZONTAL BIN UNLOADER, 2-BELT	45 lbs.	★

For 6" Powerhead Extension, add \$★/ft

### 8" UNLOADING KIT (2500 BPH)

8"x24" long, 14ga. Galv. Tube w/ flange, stubs, motor mount, 7ga. Flight welded to 1.9" O.D. tube, belt and 12" auger sheave. Use 3.0" motor pulley for proper speed.

DESCRIPTION	WEIGHT	PRICE
8" HORIZONTAL BIN UNLOADER, 1-BELT	64 lbs.	★
8" HORIZONTAL BIN UNLOADER, 2-BELT	67 lbs.	★

For 8" Powerhead Extension, add \$★/ft

### 10" UNLOADING KIT (4000 BPH)

10"x30" long, 14ga. Galv. Tube with flange, stubs, motor mount, 7ga. Flight welded to 1.9" O.D. tube, belts and 15" auger sheave. Use 3.0" motor pulley for proper speed.

DESCRIPTION	WEIGHT	PRICE
10" HORIZONTAL BIN UNLOADER, 2-BELT	118 lbs.	★

For 10" Powerhead Extension, add \$★/ft

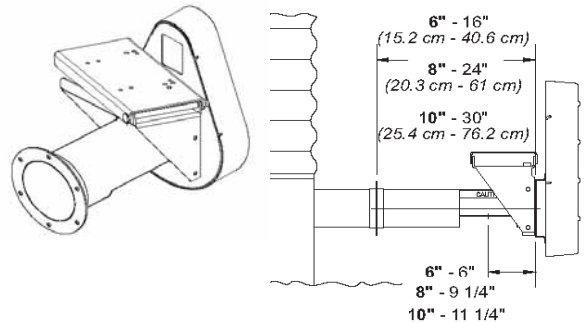

Bin Diameter	Horizontal Power		
	6"	8"	10"
14'-16'	3/4 HP	1-1/2 HP	
17'-19'	1 HP	2 HP	
20'-22'	1 HP	2 HP	
23'-25'	1 HP	3 HP	5 HP
26'-28'	1.5 HP	3 HP	5 HP
29'-31'	2 HP	5 HP	5 HP
32'-34'	2 HP	5 HP	5 HP
35'-37'	2 HP	5 HP	7.5 HP
42'		5 HP	7.5 HP
48'		5 HP	7.5 HP

## VERTICAL BIN UNLOADING AUGER KITS

Start one motor and unload grain directly into your truck, trailer or grinder mixer. One motor runs both the vertical & horizontal auger. Forget about moving your equipment back and forth to unload bins. The vertical unloader is always there, ready to go.

These units include a 16'-6" vertical auger, a horizontal section with flange to attach to the unloading tube, heavy-duty right angle gearbox with gears running in oil, hardened tooth sprockets, high quality domestic chain, universal motor mount, "B" section drive, belt guard, 45° spout head and 3' long solid spouting for the discharge. A foot support and adjustable mounting bracket are also included

### 6" VERTICAL BIN UNLOADER (1,205 BPH)

This kit includes the 16'-6" vertical auger, 6" x 16" horizontal tube with flange, right angle drive, 2-groove 12" sheave and "B" section belts, motor mount, mounting bracket, belt guard and 3' spout. Use 4.5" O.D. motor sheave. Order horizontal flight separately.

DESCRIPTION	WEIGHT	PRICE	Ext / ft.
6" VERTICAL BIN UNLOADER	239	★	★

### 8" VERTICAL BIN UNLOADER (2,500 BPH)

This kit includes the 16'-6" vertical auger, 8" x 24" horizontal tube with flange, right angle drive, 2-groove 12" sheave and "B" section belts, motor mount, mounting bracket, belt guard and 3' spout. Use 4.5" O.D. motor sheave. Order horizontal flight separately.

DESCRIPTION	WEIGHT	PRICE	Ext / ft.
8" VERTICAL BIN UNLOADER	363	★	★

### 10" VERTICAL BIN UNLOADER (3,750 BPH)

This kit includes the 16'-6" vertical auger, 10" x 24" horizontal tube with flange, right angle drive, 3-belt 12" pulley and "B" section belts, motor mount, mounting bracket, belt guard and 3' spout. Use 4.0" motor pulley. Order horizontal flight separately.

DESCRIPTION	WEIGHT	PRICE	Ext / ft.
10" VERTICAL BIN UNLOADER	505	★	★
Adapter Kit - allows 8" vertical to adapt to 6" unloading tube. 1-1/4" to 1". (6 lbs.)			★
Adapter Kit - allows 10" vertical to adapt to 8" unloading tube. Includes plate and stub. (7 lbs)			★

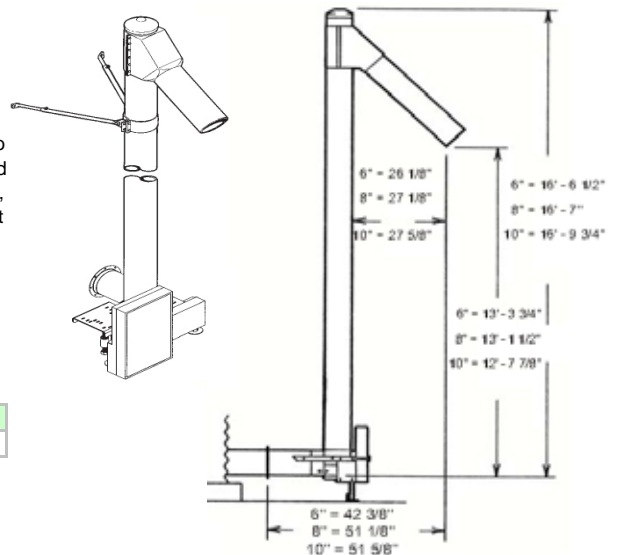

Bin Diameter	Vertical Power		
	6"	8"	10"
14'-16'	3 HP	7.5 HP	
17'-19'	3 HP	7.5 HP	
20'-22'	5 HP	7.5 HP	
23'-25'	5 HP	7.5 HP	10 HP
26'-28'	5 HP	7.5 HP	10 HP
29'-31'	5 HP	7.5 HP	10 HP
32'-34'	7.5 HP	10 HP	15 HP
35'-37'	7.5 HP	10 HP	15 HP
42'		10 HP	15 HP
48'		10 HP	15 HP