

# COMMERCIAL BIN UNLOAD

Commercial Klean Sweeps include Flight and Shield in sections no longer than 9'-9 3/4" long. Sweeps for 48' bins and larger include a Sweep Carrier Assembly. Additional carriers can be ordered.

Center portion of sweep to be used prior to adding subsequent sections until the entire sweep has been assembled and the bin unloaded.

## 68 SERIES COMMERCIAL KLEAN SWEEP FLIGHT, SHIELD, REDUCTION WHEEL AND DRIVE

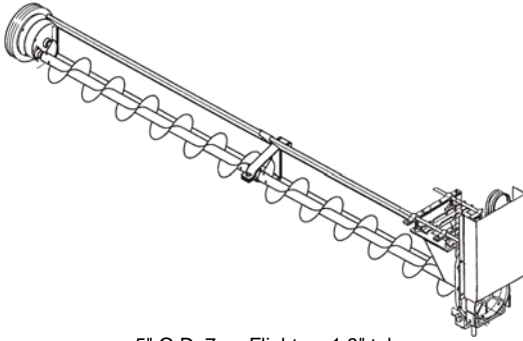

5" O.D. 7ga. Flight on 1.9" tube  
Drive includes 2 to 1 Oil Bath Reducer  
Capacity rated at ~240 BPH per 100 RPM

SECTIONS	HP	BIN DIA.	WT.	LENGTH	PRICE
2	2	24'	191	11'-4"	★
2	2	27'	201	12'-10"	★
2	2	30'	208	14'-2 1/4"	★
2	3	33'	218	15'-10"	★
2	3	34'	221	16'-4 1/2"	★
2	3	36'	225	17'-4"	★
2	3	37'	231	17'-10 1/2"	★
2	3	39'	235	18'-10 1/4"	★
2	3	40'	238	19'-4"	★
2	3	42'	242	20'-4 1/4"	★
3	3	48'	302	23'-4 1/4"	★
3	5	49'	310	23'-9 1/2"	★
3	5	54'	319	26'-4 1/2"	★
3	5	55'	330	26'-9 1/2"	★
3	5	60'	340	29'-4 1/2"	★
4	5	63'	351	30'-11"	★
4	5	68'	375	33'-4 3/4"	★
4	5	69'	386	33'-10"	★
4	5	72'	388	35'-5 1/4"	★
4	5	75'	402	36'-11"	★

LENGTH: CENTER OF BIN TO OUTSIDE OF SWEEP WHEEL

Desired Size to Match	BPH	1750 Motor Pulley	Driven Pulley	RPM
6" Unload System	787	3.0" O.D.	8.0" O.D.	328
8" Unload System	1,050	4.0" O.D.	8.0" O.D.	438

## 810 SERIES COMMERCIAL KLEAN SWEEP FLIGHT, SHIELD, REDUCTION WHEEL AND DRIVE

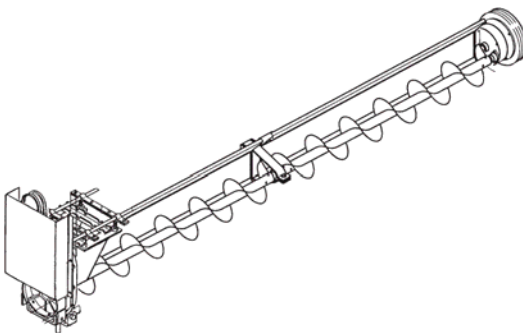

7" O.D. 7ga. Flight on 1.9" tube.  
Drive includes 2:1 Oil Bath Reducer  
with 2 belts and 10" driven pulley.  
Capacity rated at ~520 BPH per 100 RPM

SECTIONS	HP	BIN DIA.	WT.	LENGTH	PRICE
2	3	24'	2559	11'-4 1/2"	★
2	3	27'	269	12' 10 1/2"	★
2	3	30'	279	14'-2 3/4"	★
2	3	33'	292	15'-10 1/2"	★
2	3	34'	3090	16'-5"	★
2	3	36'	316	17'-4 3/4"	★
2	3	37'	319	17'-11"	★
2	3	39'	326	18'-10 3/4"	★
2	3	40'	329	19'-4 1/2"	★
2	3	42'	336	20'-5"	★
3	5	48'	410	23'-5"	★
3	5	49'	421	23'-10 1/4"	★
3	5	54'	430	26'-5 1/4"	★
3	5	55'	432	26'-10 1/4"	★
3	5	60'	461	29'-5 1/4"	★
4	7.5	63'	181	30'-11 1/2"	★
4	7 1/2	68'	504	33'-5 1/4"	★
4	7.5	69'	506	33'-10 1/2"	★
4	7 1/2	72'	531	35'-5 3/4"	★
4	7.5	75'	552	36'-11 1/2"	★
4	7 1/2	78'	562	38'-5 3/4"	★
4	7.5	80'	562	39'-5 1/2"	★
4	7 1/2	82'	576	40'-5 1/4"	★
5	7.5	90'	644	44'-6 1/4"	★
5	7 1/2	92'	657	45'-6"	★

LENGTH: CENTER OF BIN TO OUTSIDE OF SWEEP WHEEL

Desired Size to Match	BPH	1750 Motor Pulley	Driven Pulley	RPM
8" Unload System	1,591	3.5" O.D.	10.0" O.D.	306
10" Unload System	2,049	4.5" O.D.	10.0" O.D.	394