

COMMERCIAL BIN UNLOAD

Commercial Klean Sweeps include Flight and Shield in sections no longer than 9'-9 3/4" long. Sweeps for 48' bins and larger include a Sweep Carrier Assembly. Additional carriers can be ordered. Center portion of sweep to be used prior to adding subsequent sections until the entire sweep has been assembled and bin unloaded.

1012 SERIES COMMERCIAL KLEAN SWEEP FLIGHT, SHIELD, REDUCTION WHEEL AND DRIVE

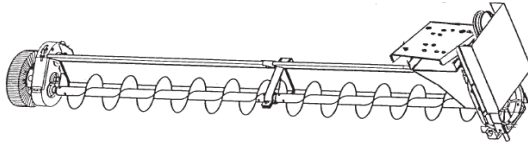

9" O.D. 1/4" Flight on 2 7/8" tube
Drive includes 3 to 1 Oil Bath Reducer
Capacity rated at ~1280 BPH per 100 RPM

SECTIONS	HP	BIN DIA.	WT.	LENGTH	PRICE
2	3	24'	438	11'-5 5/8"	★
2	3	27'	451	12'-11 5/8"	★
2	3	30'	476	14'-3 7/8"	★
2	3	33'	490	15'-11 5/8"	★
2	3	34'	498	16'-6 1/8"	★
2	3	36'	511	17'-5 7/8"	★
2	3	37'	515	18'-1/8"	★
2	5	39'	529	18'-11 7/8"	★
2	5	40'	536	19'-5 5/8"	★
2	5	42'	550	20'-6 1/8"	★
3	5	45'	622	22'-1/8"	★
3	5	48'	649	23'-6 1/8"	★
3	5	49'	658	23'-11 3/8"	★
3	5	54'	688	26'-6 3/8"	★
3	5	55'	697	26'-11 3/8"	★
3	7 1/2	60'	727	29'-6 3/8"	★
4	7 1/2	63'	750	31'-1"	★
4	7 1/2	68'	785	33'-6 3/4"	★
4	7 1/2	69'	795	34'-0"	★
4	7 1/2	72'	810	35'-4 3/8"	★
4	7 1/2	75'	827	37'-1"	★
4	10	78'	849	38'-7 1/4"	★
4	10	80'	863	40'-1/2"	★
4	10	82'	880	40'-6 3/4"	★
5	10	90'	974	44'-7 3/8"	★
5	10	92'	1022	45'-7 1/8"	★
6	10	105'	1101	51'-6 1/8"	★
6	10	113'	1237	55'-6 1/8"	★
6	15	120'	1246	59'-3/8"	★

LENGTH: CENTER OF BIN TO OUTSIDE OF SWEEP WHEEL

Center sweep carrier(s) provided on 48' through 82' diameter bins. Two carriers are furnished with units for 90' bins and larger.

Desired Size to Match	BPH	1750 Motor	Driven Pulley	RPM
10" Unload System	3,200	5.0" O.D.	12.0" O.D.	250
12" Unload System	3,712	6.0" O.D.	12.0" O.D.	290

1214 SERIES COMMERCIAL KLEAN SWEEP FLIGHT, SHIELD, KLEAN SWEEP TRACTOR AND DRIVE

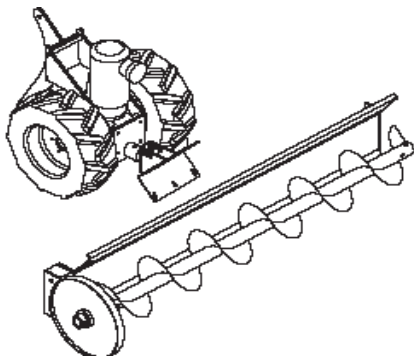

12" O.D. 1/4" Flight on 2 7/8" tube

Drive includes 3 to 1 Oil Bath Reducer - 36' through 78' diameter bins.

Drive includes 4 to 1 Oil Bath Gear Reducer - 80' through 120' diameter bins.

Motor Pulley not included. Pivot pin support is Ø1"

Capacity rated at ~2700 BPH per 100 RPM

SECTIONS	HP	BIN DIA.	WT.	LENGTH	PRICE
2	7 1/2	36'	448	17'-1"	★
2	7 1/2	37'	456	17'-7"	★
2	7 1/2	40'	474	19'-1"	★
2	10	42'	493	19'-9"	★
2	10	43'	501	20'-6"	★
3	10	48'	563	23'-0"	★
3	10	49'	565	23'-6"	★
3	15	54'	611	26'-0"	★
3	15	55'	618	26'-6"	★
3	15	59'	649	28'-7"	★
3	15	60'	657	29'-0"	★
3	15	62'	668	29'-8"	★
4	15	68'	735	33'-10"	★
4	15	72'	767	34'-10"	★
4	15	75'	793	36'-5"	★
4	15	78'	816	37'-11"	★
4	20	80'	937	39'-0"	★
5	20	88'	1015	42'-10"	★
5	20	90'	1028	43'-8"	★
5	20	92'	1041	44'-7"	★
6	20	105'	1164	51'-1"	★
6	25	113'	1224	55'-0"	★
6	25	120'	1279	58'-5"	★

LENGTH: CENTER OF BIN TO OUTSIDE OF SWEEP WHEEL

Tractor includes reduction drive gearbox. For bin diameters of 60 ft. and greater, the tractor includes cast iron weights. For bin diameters 68' through 92', one sweep carrier is provided. Two carriers are furnished with units for 105' bins and larger.

Desired Size to Match	BPH	1750 Motor	Driven Pulley	RPM
12" Unload System w/ 3:1 Chain Drive	3,942	3.0" O.D.	12.0" O.D.	146
12" Unload System w/ 3:1 Chain Drive	4,590	3.5" O.D.	12.0" O.D.	170
12" Unload System w/ 3:1 Chain Drive	5,886	4.5" O.D.	12.0" O.D.	170
12" Unload System w/ 5:1 Chain Drive	4,887	4.6" O.D.	9.4" P.D.	181
12" Unload System w/ 5:1 Chain Drive	5,292	5.0" O.D.	9.4" P.D.	196
12" Unload System w/ 5:1 Chain Drive	5,886	5.6" O.D.	9.4" P.D.	218
12" Unload System w/ 5:1 Chain Drive	6,102	6.0" O.D.	9.4" P.D.	226